

LZB-600-R10 Cubic Shape Vacuum Packer

i. Applications

Used for the quantitative brick shape vacuum packaging in the industry of rice, grains, peanuts, and food etc.

ii. Technical parameters:

Model	LZB-600-R10
Weighing extent (kg)	0.5-5
Speed(bags/h)	540-600(the speed range is for 0.5-5kg)
Scale Interval(gram)	1
Precession grade	X(0.5)
Power	4N-AC 380V 50Hz 4.5KW
Air , air consumption	0.4-0.6MPa 6m ³ /h (supplied by the customer)
Height (mm)	2500

iii. Main Configures:

NO.	Name:	Main Configures
1	Touch screen 10"	Japan / Omron
2	Weighing controller	Canada/General
3	PLC	Japan / Omron
4	Switching Power Supply	Japan / Omron
5	Solid state relay	Japan / Omron
6	Intermediate relay	Japan / Omron
7	Load cell	USA/VPG
8	Phase sequence protection relay	France / Schneider
10	Vacuum pump	Germany
11	Cylinder	Taiwan/Airtac
12	Solenoid valve	Taiwan/Airtac
13	Linear Slides	Taiwan/ABBA

iv. Functions and Features

- New generation of high-speed weighing control mode parameter automatic correction, adaptive weighing process various materials;
- Omron touch screen, Omron PLC centralized control, intelligent control weighing, filling, six-sided plastic,
- Vacuum, heat sealing, unloading bags, the whole process of transportation, real-time tracking system working state, friendly interface, easy to operate;
- high reliability and long service life;

 **佳龙 Zhangzhou Jialong Technology Inc.**

- imported from Germany, vacuum pumps, stable and reliable;
- device with fault self-test function, maintenance is simple and convenient;
- intelligent control information presentation system;
- Automatic Bag interface reserved.
- Reserve RS232/485



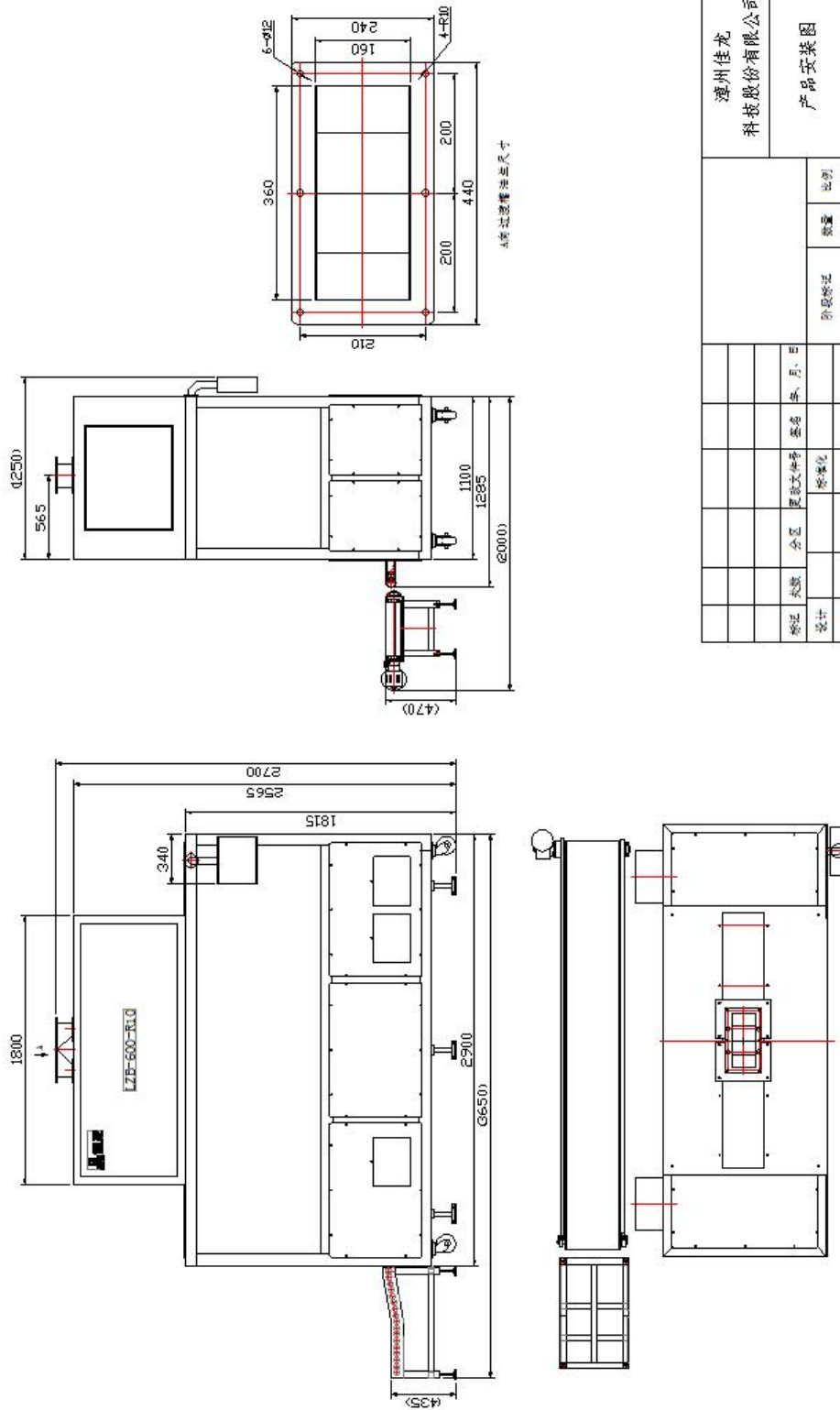

漳州佳龙 科技股份有限公司		产品安装图		LZB-600-R10	
设计	审核	会签	批准	日期	比例
					1:1
共 1 张 第 1 张					

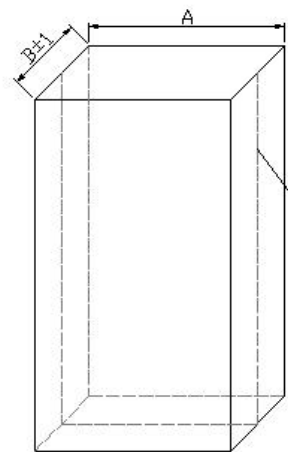

样袋展开图

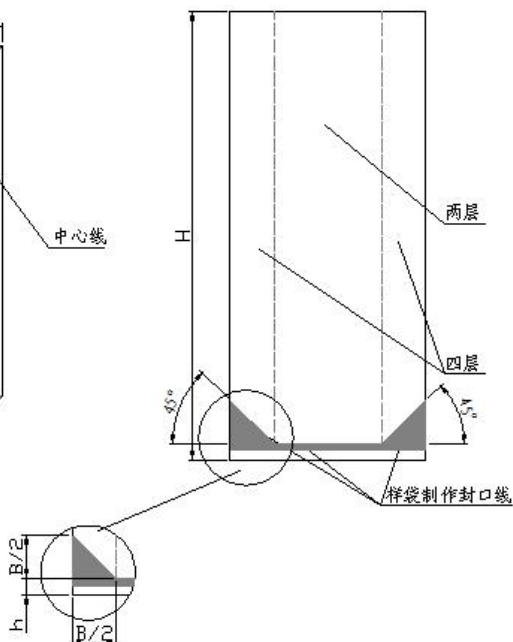

品名	规格	材质
5.0kg空白风琴袋	460×230+80	BOPx15/PE120
2.5kg空白风琴袋	390×180+60	BOPx15/PE110
1.0kg空白风琴袋	320×100+60	BOPx15/PE95
0.5kg空白风琴袋	290×80+40	BPx15/PE90

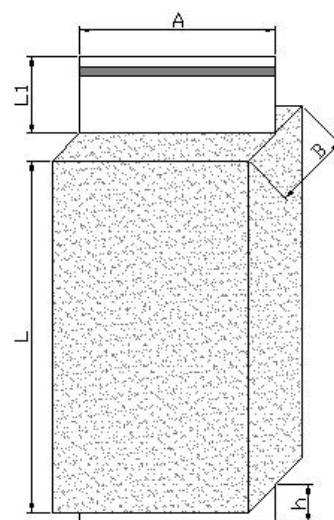

技术要求

- 1、风琴袋厚度 $\delta = 0.10 \sim 0.14\text{mm}$
- 2、气密性与热封性能良好
- 3、保证中心线位置，不允许错位

包装规格	A×B (mm)	H (mm)	b (mm)	δ (um)	R3/R6/R7	R5/R10	成型高度L (mm)
5.0kg	230×80	460	不大于15	135		300	
2.5kg	180×60	390	不大于15	125	240	250	
1.0kg	100×60	320	不大于15	110	175	185	
0.5kg	80×40	290	不大于15	105	165	170	

风琴包装袋制作参考尺寸明细表

漳州佳龙科技股份有限公司

风琴包装袋
尺寸规格